

HS-215S-IN Outdoor- housing



Key Features

- Anti-corrosive and ultraviolet-proof material to enhance outdoor durability
- Combined with adjustable sun shade from direct solar radiation
- Easy and flexible installation with side open structure
- IP66-rated

Specifications

Housing	HS-215S-IN
Application	Indoor or Outdoor (including sun shade)
Ingress Protection	IP66
Operating Condition	-20°C ~50°C (-4°F ~ 122°F) Humidity ≤ 90% RH(non-condensing)
Dimensions (L × W × H)	Outside: 430×170.6×104mm (16.9"×6.7" ×4.1") Inside: 280×100×80mm (11.0"×3.9"×3.1")
Weight	1.5 kg (3.3lb)
Material	Shell: aluminum alloy Front and rear lids: plastic ABS

Dimensions

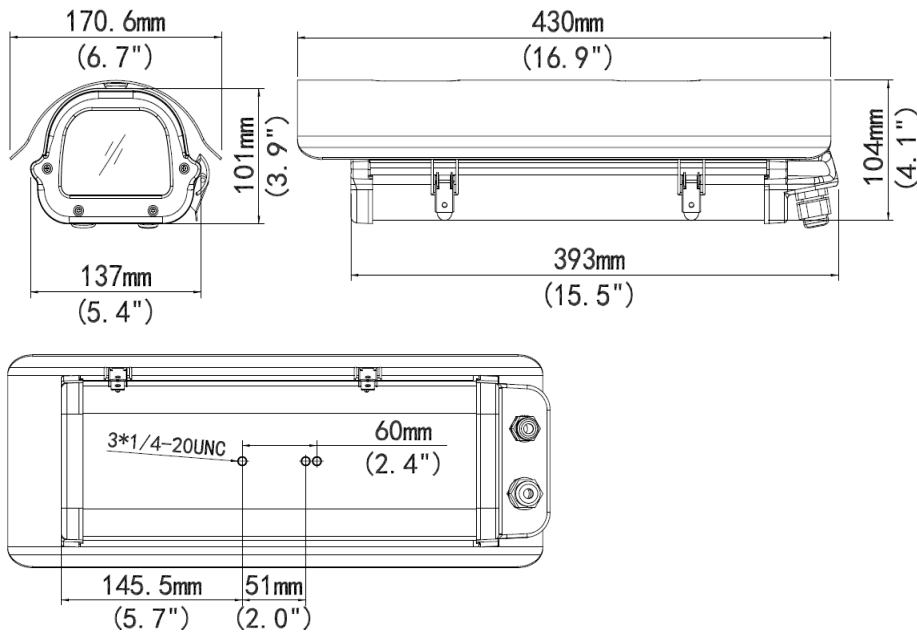

Accessories

Installation mode	Accessories	Description
Pendant mount	TR-CM06-IN	/
Wall mount	Indoor: TR-WM06-A-IN Outdoor: TR-WM06-B-IN	/
Rail mount	TR-UV06-A-IN + TR-UP06-IN	/
Standing pole mount	TR-WM06-B-IN + TR-UP06-IN	/
Pole mount	TR-UV06-A-IN	/

Zhejiang Uniview Technologies Co.,Ltd.

South Tower, Building 10, Wanlun Science Park, 88 Jiangling Road, Hangzhou, P.R.China 310051

Email: overseasbusiness@uniview.com; globalsupport@uniview.com

<http://www.uniview.com>

©2015 Zhejiang Uniview Technologies Co.,Ltd. All rights reserved.

*Product specifications and availability are subject to change without notice.